



# LumiStreet gen2

## BGP292 LED99-4S/740 I DX10 7024 D9 76S

LUMISTREET GEN2 MINI - LED module 9900 lm - 740 neutral white - Safety class I - Distribution extra-wide 10 - Side-entry for diameter 76 mm

Increasing numbers of municipalities are having to upgrade large-scale conventional street lighting installations with energy-efficient LED technology. But they are having to do this with smaller and smaller budgets. That's why the new generation of LumiStreet has been upgraded and designed to provide a solution to this challenge, it is the ideal solution for performing point-to-point replacement of conventional lighting. LumiStreet gen2 achieves this by offering high-efficiency, low Total Cost of Ownership and ease of installation and maintenance. The ease of installation and maintenance is enabled by the Philips Service tag. Moreover, the Philips SR (System Ready) socket makes it future-ready and you can pair this luminaire with lighting control and software applications such as Interact City.

### Product data

General Information		Protection class IEC	Safety class I
Lamp family code	LED99 [ LED module 9900 lm]	Flammability mark	F [ For mounting on normally flammable surfaces]
Light source colour	740 neutral white	CE mark	CE mark
Light source replaceable	Yes	ENEC mark	ENEC plus mark
Number of gear units	1 unit	Warranty period	5 years
Driver/power unit/transformer	PSD [ Power supply unit with DALI interface]	Optic type outdoor	Distribution extra-wide 10
Driver included	Yes	Remarks	* At extreme ambient temperatures the luminaire might automatically dim down to protect components
Optical cover/lens type	FG [ Flat glass]	Constant light output	No
Luminaire light beam spread	150° - 43° x 67°	Number of products on MCB (16 A type B)	10
Control interface	DALI		
Connection	2 push-in connectors 5-pole		
Cable	-		

# LumiStreet gen2

EU RoHS compliant	Yes
Light source engine type	LED
Serviceability class	Class A, the luminaire is equipped with serviceable parts (when applicable): LED board, driver, control units, surge-protection device, optics, front cover and mechanical parts
Product family code	BGP292 [ LUMISTREET GEN2 MINI]

## Light Technical

Upward light output ratio	0
Standard tilt angle post-top	0°
Standard tilt angle side entry	0°

## Operating and Electrical

Input Voltage	220 to 240 V
Input frequency	50 to 60 Hz
Inrush current	47 A
Inrush time	0.25 ms
Power factor (min.)	0.99

## Controls and Dimming

Dimmable	Yes
----------	-----

## Mechanical and Housing

Housing material	Aluminium die-cast
Reflector material	Polycarbonate
Optic material	Polymethyl methacrylate
Optical cover/lens material	Glass
Fixation material	Aluminium
Mounting device	76S [ Side-entry for diameter 76 mm]
Optical cover/lens shape	Flat
Optical cover/lens finish	Clear
Overall length	620 mm
Overall width	234 mm
Overall height	95 mm
Effective projected area	0.0251 m <sup>2</sup>
Colour	Grey
Dimensions (height x width x depth)	95 x 234 x 620 mm (3.7 x 9.2 x 24.4 in)

## Approval and Application

Ingress protection code	IP66 [ Dust penetration-protected, jet-proof]
Mech. impact protection code	IK08 [ 5 J vandal-protected]
Surge protection (common/differential)	Luminaire surge protection level up to 6 kV differential mode and 8 kV common mode

## Initial Performance (IEC Compliant)

Initial luminous flux (system flux)	8300 lm
Luminous flux tolerance	+/-7%
Initial LED luminaire efficacy	134 lm/W
Init. Corr. Colour Temperature	4000 K
Init. Colour rendering index	70
Initial chromaticity	(0.381, 0.379) SDCM <5
Initial input power	62 W
Power consumption tolerance	+/-11%
Init. colour rendering index tolerance	+/-2

## Over Time Performance (IEC Compliant)

Control gear failure rate at median useful life 100,000 h	10 %
Lumen maintenance at median useful life* 100,000 h	L96

## Application Conditions

Ambient temperature range	-40 to +50 °C
Performance ambient temperature Tq	25 °C
Maximum dimming level	0% (digital)

## Product Data

Full product code	871951410031200
Order product name	BGP292 LED99-4S/740 I DX10 7024 D9 76S
EAN/UPC – product	8719514100312
Order code	10031200
SAP numerator – quantity per pack	1
Numerator – packs per outer box	1
SAP material	910925866766
SAP net weight (piece)	5.260 kg



# LumiStreet gen2

## Dimensional drawing

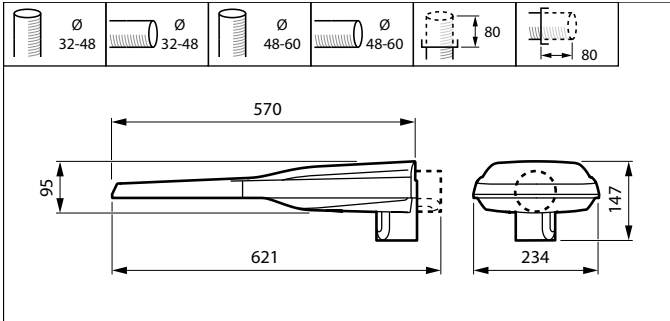

UniStreet BGP/BGS202/203/204

## Photometric data

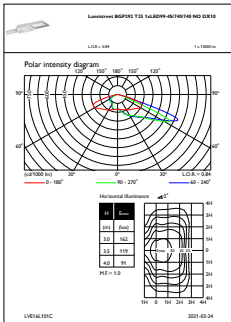

OFPL1\_

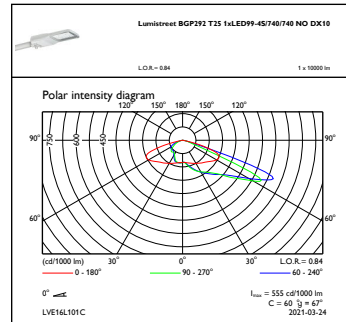

OFPC1\_

